

GAMMA instabus

Solar protection actuator 2 x 6 A DC

RL 524D23



The solar protection actuator is used to control shutters, awnings, sunblinds or ventilation flaps with DC 24 V.

- End position detection by current detection for automatic move time determination.
- Built-in device for installation in an automation module box AP 118 or in a M 590 DIN rail housing, which has to be ordered separately
- Maintenance-free terminals for connecting and looping through solid, stranded and fine-stranded conductors.

Functions for configuration with ETS:

- Extensive control and override functions and status messages for each channel
- On-site control of the drives
- Direct moving to element or slat positions.
- Automatic control of the drives with configurable behavior when the sun is shining (sun tracking control)
- Scene control for calling up and storing defined element positions
- Safety functions through overrides in case of wind, rain, frost, moving blocks etc.

Characteristics

The solar protection actuators are used to control blinds, roller shutters, sliding shutters, external blinds, awnings or ventilation flap drives with DC 24 V. They are used in building automation. Device control is conducted via KNX.

Through the selection of various operating modes such as manual and automatic mode, solar protection is controlled both locally and centrally. Automatic commands from a weather station enable sun tracking control with shade edge tracking.

The device is designed for installation in an automation module box AP 118 or a M 590 DIN rail housing, which has to be ordered separately

The bus connection of the device uses a bus terminal block. The electronics of the device are supplied via the bus voltage (no additional supply voltage required).

The maintenance-free terminals are for connecting solid, fine-stranded and stranded conductors with conductor cross-sections from 0.5 to 2.5 mm² to the relay output channels. Stranded and fine-stranded conductors can be plugged into the terminals without ferrules. DC 24 V FELV is supplied centrally via separate connection terminals to control the motor drives.

Solar protection actuator RL 524D23 consists of the device (hardware) and the application program (software). Depending on its use, each relay output channel can be assigned different functions.

Functions

Factory settings

In the factory settings, the functions “manual operation solar protection“ up/down and “manual operation stop, slats” open/close are assigned to the building site function for all channels (outputs).

Building site function

In the factory settings, the building site function enables moving up and down as well as stopping and changing the slat position of an element via a corresponding bus button, even if these devices are yet to be commissioned via the Engineering Tool Software (ETS).

Programming mode

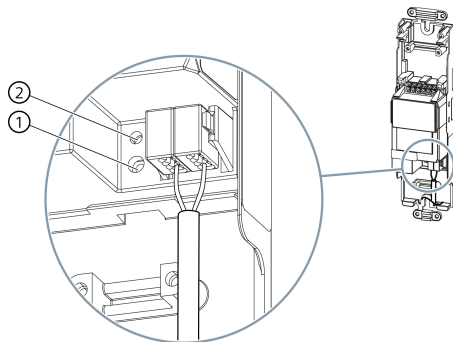

Fig. 1: Programming button and programming LED (exemplary illustration)



After bus voltage recovery, wait several seconds before pushing the programming (1) button (not before booting is complete).

Activating programming mode

- ◆ Briefly press the programming button (1) (< 2 seconds).
- ⇒ Programming mode is activated.
- ⇒ The programming LED (2) illuminates continuously.

Deactivating programming mode

- ✓ Programming mode is activated. The programming LED (1) lights up continuously.

- ◆ Briefly press the programming button (1) (< 2 seconds).
- ⇒ Programming mode is deactivated.
- ⇒ The programming LED (2) is not illuminated.

Resetting the device to factory settings

A very long push of the programming button of more than 20 seconds resets the device to its factory settings. This is indicated by the programming LED flashing steadily for 8 seconds. All configuration settings are deleted. The building site function of the delivery state is re-activated.

Behavior on unloading the application program

After unloading the application program with the ETS, the unloaded device has no functions.

Behavior on voltage failure/recovery

The electronics of the device are bus powered. Therefore, a grid voltage failure only leads to a functional failure of the device if the bus voltage also fails as a result of the grid voltage failure.

In case of bus voltage failure, the current status and other values for each channel are saved permanently so that they can be restored when the bus voltage is recovered.

When bus voltage is recovered, the configured actions for each channel are executed and, depending on the parameters set, new statuses are reported.

Each channel can be independently configured with parameters to define what status it is to assume in case of bus voltage failure (up, down, no change or stop). In addition, a starting behavior when bus voltage is recovered can be configured for each active override (e.g. alarms, moving blocks).

When bus voltage is recovered, one of the following functions can be selected as the starting value: Up, down, no change, as per parameter and stop. A delay can be configured for the starting value.

End position detection and automatic move time determination

The move time to defined element positions between the end positions can be analyzed automatically.

To this end, current detection is used to detect if the upper or lower end position is reached in the context of the respective Up/Down command.

Direct control commands: Move Up / Down, Stop, Slat Adjustment

1-bit objects can be used to control the moving direction of the solar protection via Up and Down commands.

In the "Shutter" operating mode, an ongoing blind move for the respective channel can be stopped or, if the blind is stationary and a logical "0" is received, the slats can be opened by one step; if a logical "1" is received, they can be closed by one step.

Direct control commands: Move to positions 0...100 %

1-byte objects can be used to move the sunblind of the corresponding channel to any position between 0 and 100 % in manual operation and automatic operation.

In "Shutter" operating mode, the slats of the corresponding channel can also be moved into any position between 0 and 100 %.

Scene control

8-bit scene control

Using 8-bit scene control, current solar protection or slat positions can be assigned to a scene and retrieved.

Move to position 1/2, 3/4 (1-bit scene control)

The function "move to position 1/2, 3/4" is particularly suitable to repeatedly move to preferred element positions in combination with the 1-bit scene control.

The function can be used to specify 4 different solar protection positions for each channel. 2 of these preset positions (1/2 or 3/4) are addressed via one group address with the values "0" and "1."

The stored default settings of the positions can also be changed without programming the device via KNX. To do this, the blinds must be moved to the desired element height. This new position with the value "0" and "1" is copied to the memory of the device via the communication objects "position 1/2" (store) and "position 3/4" (store).

A preferred blind position can be called and stored at the push of a button. To do this, a key is pressed briefly to call up a position and a long key press is used to store it as a desired position.

Manual operation/automatic operation

The "manual operation" and "automatic operation" functions can be released separately for each channel via the ETS.

Manual operation is used for on-site control of the drives either individually or as a central command. Direct moving to element or slat positions is also possible here.

Automatic operation is configured for automated control of drives via a weather station. Automatic control via central commands is also possible.

When the sun is shining, sun tracking control of slats or shadow line tracking is implemented.

Central control

Each solar protection channel can be controlled centrally in manual operation and in automatic operation (manual operation solar protection central, automatic operation solar protection central). In addition, an individual delay time can be configured for time-delayed operation of the solar protection to avoid load peaks and noise pollution when starting up several drives.

Overrides

Up to seven different override function blocks can be activated via ETS to override the solar protection functions. The overrides can be configured per channel and individually.

For each of the override function blocks, one of the following functions can be selected: Wind Alarm, Rain Alarm, Frost Alarm, Lock, Forced position, Forced Control, Range limitation, User defined.

This enables flexible configuration of an individual priority-specific override for each channel. For the override functions a control value input can be selected instead of a switching control input.

Different priorities can be assigned to the override functions.

Range limitation

In order to not disturb the movement of the solar protection when windows, doors or skylights are open, the movement range can be restricted with an upper and lower limit.

Element settings

For exact positioning and adjustment of the elements, the move times between the respective end positions can be determined automatically. For this purpose, there are calibration runs, which can be configured.

An end position dead time can also be set for this.

Alternatively, the move times of the elements or the slat move times and step sizes for slats (shutters) can be set manually.

Advanced configuration

Specific settings for controlling the drives are offered. This includes, e.g. the swapping of the UP and DOWN connections. A reverse pause time is set to protect the motor.

A slip compensation time can be projected as slip compensation for a change in direction.

The drives can be controlled with start-up delays or run on for a configured time.

Status messages

Responses on element positions, such as dynamic element position, slat position, moves, moving directions, reaching the upper or lower end position are reported. In addition, responses to the different overrides and the current operating mode, such as automatic operation, can be displayed. In automatic end position detection, a status on the calibration of the move time is communicated.

Diagnostic functions

Contact faults can be reported.

Schematic design of a solar protection actuator channel

The following scheme shows the function of a channel of the solar protection actuator using the "blind" function in a logical context.

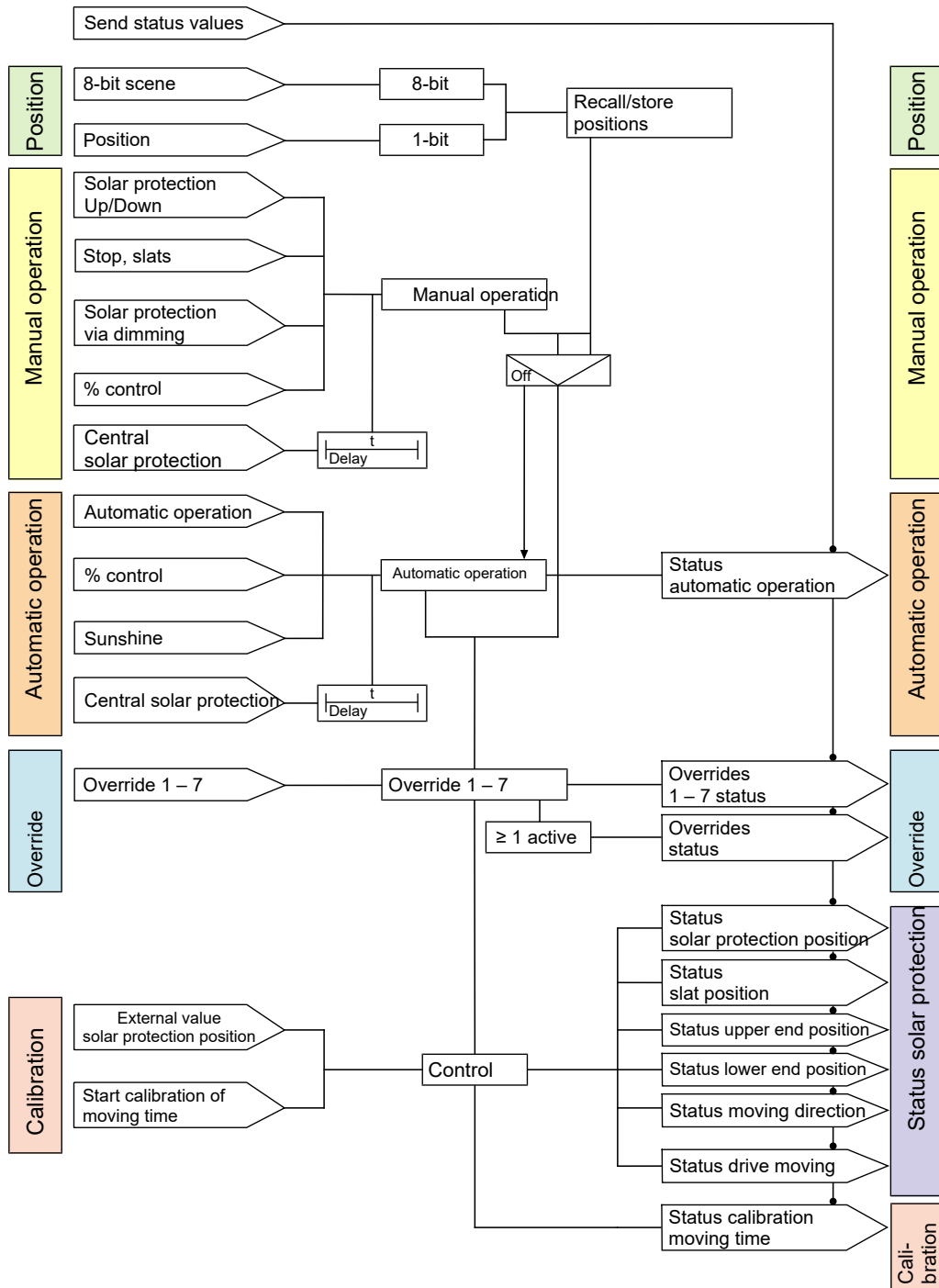

Position and function of the operating and display elements and connections

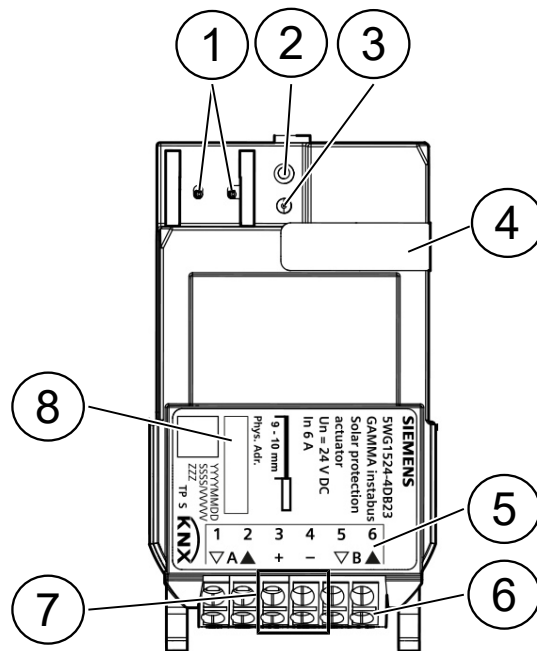



Fig. 2: Position and function of the connections and labeling, operating and display elements Solar protection actuator RL 524D23, 2 x 6 A DC

| Pos. | Connection, operating or display element | Function |
|------|---|---|
| 1 | Connection pins for KNX bus terminal block | Connect KNX bus |
| 2 | Programming button | Short push of button (< 2 s): |
| 3 | Programming LED (red) | <ul style="list-style-type: none"> • Activate programming mode, display status (programming LED on = active) Very long push of button (> 20 s): <ul style="list-style-type: none"> • Reset to factory settings (programming LED starts flashing after 20 s) |
| 4 | Label with barcode of the device | Two copies of the barcode are printed on it. The second barcode can be separated to facilitate commissioning and, for example, be kept with the documents for the project. |
| 5 | Labeling of switching contacts for the channels and input terminals | |
| 6 | Connection terminals of the channels | Connect motors |
| 7 | Feed in 24 V DC for all channels (motors) | |
| 8 | Label field | Enter physical address |

Type overview

| Type | Designation | Item number | KNX PL-Link |
|--|---|---------------|-------------|
|  RL 524D23 | Solar protection actuator, 2 x 6 A, DC 24 V | 5WG1524-4DB23 | yes |

Scope of delivery

Module for installation in AP 118 automation module box or M 590 DIN rail housing.

Accessories



| Type | Order number | Designation |
|---|---------------|------------------------------|
|  | 5WG1118-4AB01 | Automation module box AP 118 |
|  | 5WG1590-8AB01 | DIN rail housing M 590 |

Table 1: Automation module box AP 118 and DIN rail housing M 590

Version of the Engineering Tool Software

| Application | Version |
|---------------------------------|----------------|
| Engineering Tool Software (ETS) | ETS 5 or above |

Product documentation and support

Product documentation

Documents related the product, such as operating and installation instructions, application program description, product database, additional software and CE declarations can be downloaded from the following website:

<http://www.siemens.com/gamma-td>



Frequently asked questions

For frequently asked questions about the product and their solutions, see:

<https://support.industry.siemens.com/cs/products?dtp=FAQ&mfn=ps&lc=en-WW>



Support

Contact details for additional questions relating to the product:

Tel.: +49 89 9221-8000



Notes

Security

The device is designed to be installed in an AP 118 automation module box or a M 590 DIN rail housing.

! CAUTION



National safety regulations

Failure to comply with national safety regulations may result in personal injury and property damage.

- Observe national provisions and comply with the appropriate safety regulations.



- The device should only be installed and put into operation by a certified electrician.
- When connecting the device, ensure that the device can be enabled.
- Do not open the casing of the device.
- Only use conventional transformers that comply with the relevant standards and contain a thermal fuse.
- For planning and setup of electric systems, the relevant guidelines, observe the regulations and standards of the respective country.
- Secure the phases with a B10 line protection switch.

Commissioning



Areas of use

The device is installed in an automation module box AP 118 in dry interior spaces.

Connecting motors to the relay contacts

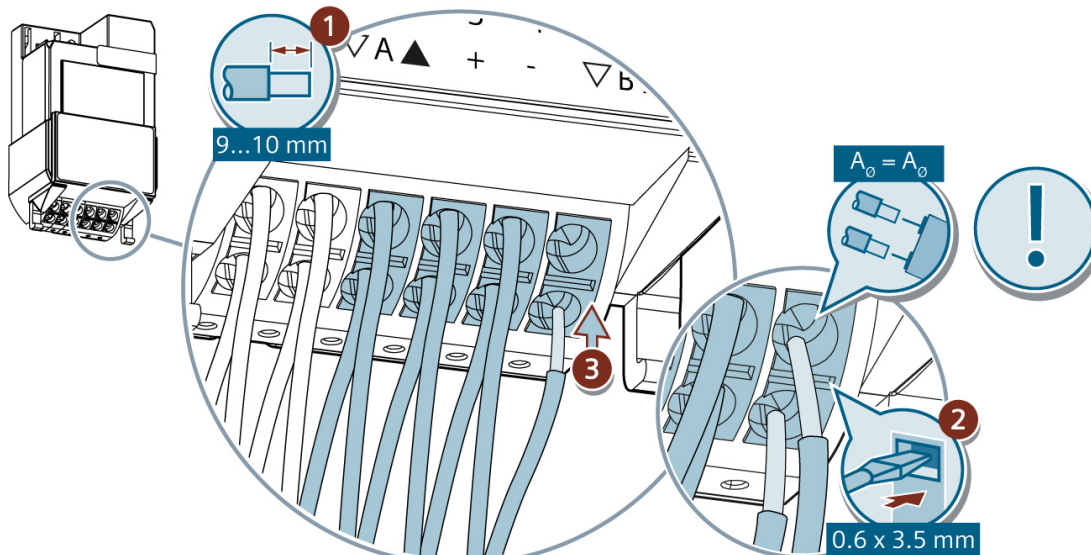



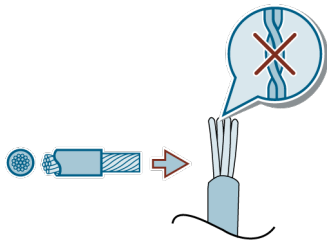

Fig. 3: Solar protection actuator RL 524D23, 2 x 6 A DC



| | |
|---|---------------------------|
|  | 0.5...2.5 mm ² |
|  | |
|  | 2.5 mm ² |



Connecting KNX

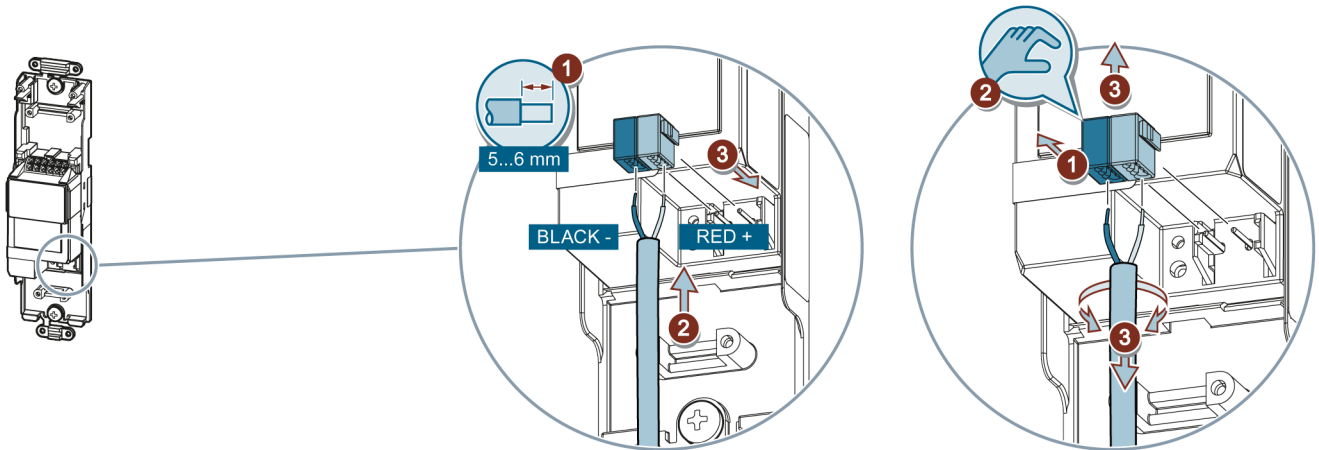



Fig. 4: Solar protection actuator RL 524D23, 2 x 6 A DC

| | |
|---|---|
| Cu |  |
|  | 0.6...0.8 mm |

Testing KNX 24 V DC type. SELV

This test can be used to check whether the bus connection cable is connected with the correct polarity and whether device is supplied with bus voltage.

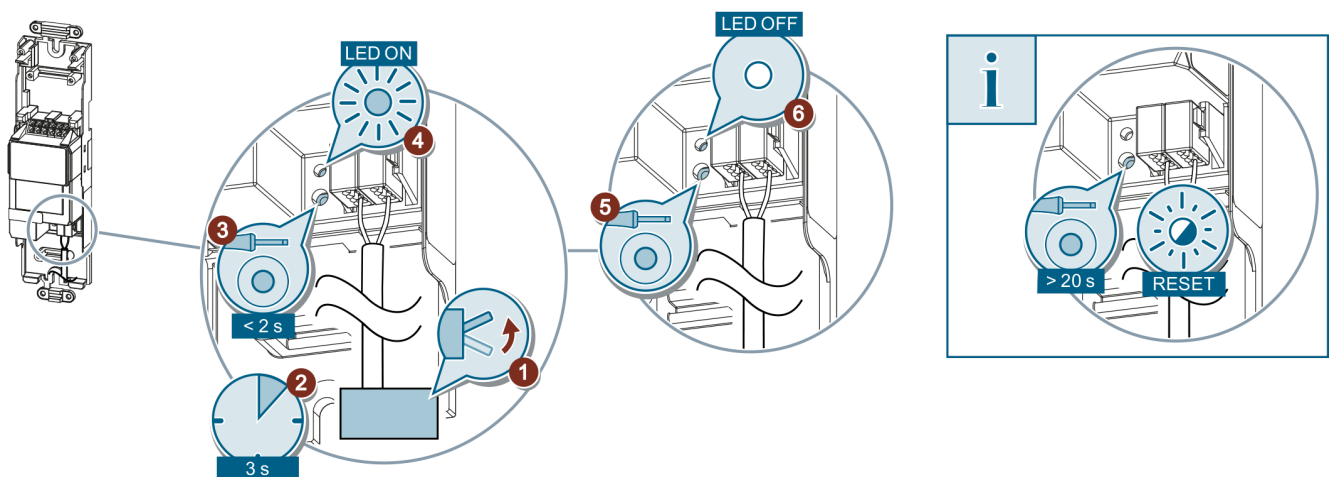

Fig. 5: Solar protection actuator RL 524D23, 2 x 6 A DC

If the programming button is pushed for more than 20 seconds, the device is reset to its factory settings.

Disposal



The device is considered an electronic device for disposal in accordance with European Directive and may not be disposed of as domestic waste.

- Use only designated channels for disposing the devices.
- Comply with all local and currently applicable laws and regulations.



If a device is defective, contact the local sales office.

| Power supply | |
|------------------------------------|------------------------|
| KNX bus voltage | DC 24 V (DC 21...30 V) |
| KNX power consumption | 15 mA |
| KNX power loss (power consumption) | 0.15 W |

| Outputs | |
|---|----------|
| Number of drive channels | 2 |
| Switching voltage | DC 24 V |
| Output current | |
| Rated current per channel | 6 A |
| Rated current per device | 10 A |
| Current sensing for move time determination | > 150 mA |

| Service life | |
|--|-----------------------------|
| Mechanical lifespan | 10,000,000 switching cycles |
| Electrical lifespan | 50,000 switching cycles |
| Power loss | |
| Maximum power loss of the device at rated output | 3 W |
| Maximum power loss per output at rated output and maximum resistive load | 1.8 W |
| Switching capacities/load types, loads | |
| Resistive load | 144 W |
| Minimum switching capacity | 5 V 100 mA |
| DC1 switching capacity | 24 V 6 A |

| Mechanical data | |
|------------------------|--|
| Housing material | Plastic |
| Dimensions | See Dimension drawing [▶ 13] |
| Product weight | 82 g |
| Fire load | 2 MJ |

| Environmental conditions | |
|------------------------------------|-----------------------------------|
| Ambient temperature in operation | -5 °C...+45 °C (23 °F...113 °F) |
| Storage temperature | -20 °C...+70 °C (-4 °F...158 °F) |
| Transport temperature | -25 °C...+70 °C (-13 °F...158 °F) |
| Relative humidity (non-condensing) | 5 %...95 % |
| Environmental rating | EN 60721-3-3 class 3k5 |

| Protection settings | |
|--|-----|
| Degree of pollution (according to IEC 60664-1) | 2 |
| Over-voltage category (according to IEC 60664-1) | III |

| Protection settings | |
|--|---------------------------------|
| Housing protection class (according to EN 60529) | IP20 (when installed AP 118) |
| Electrical safety, bus (SELV) | yes |
| Electrical safety, device fulfills | EN 50428 |
| EMC requirements, device complies with | EN 50428 |
| Test mark | KNX, EAC, RCM, WEEE, China-RoHS |
| CE mark | yes |

| Reliability | |
|------------------------|----------|
| Failure rate (at 40°C) | 1024 fit |

Connection example

The following connection example shows the connection of 2 DC motors for control (up/down or open/close) e.g. of solar protection, door, window or ventilation flaps via channels A and B.

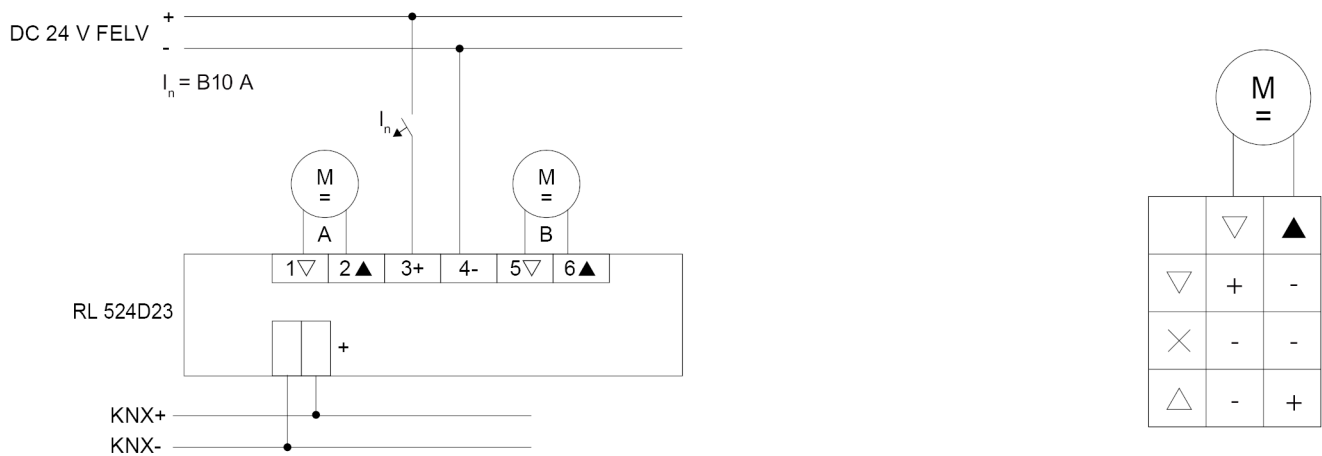

Dimension drawing

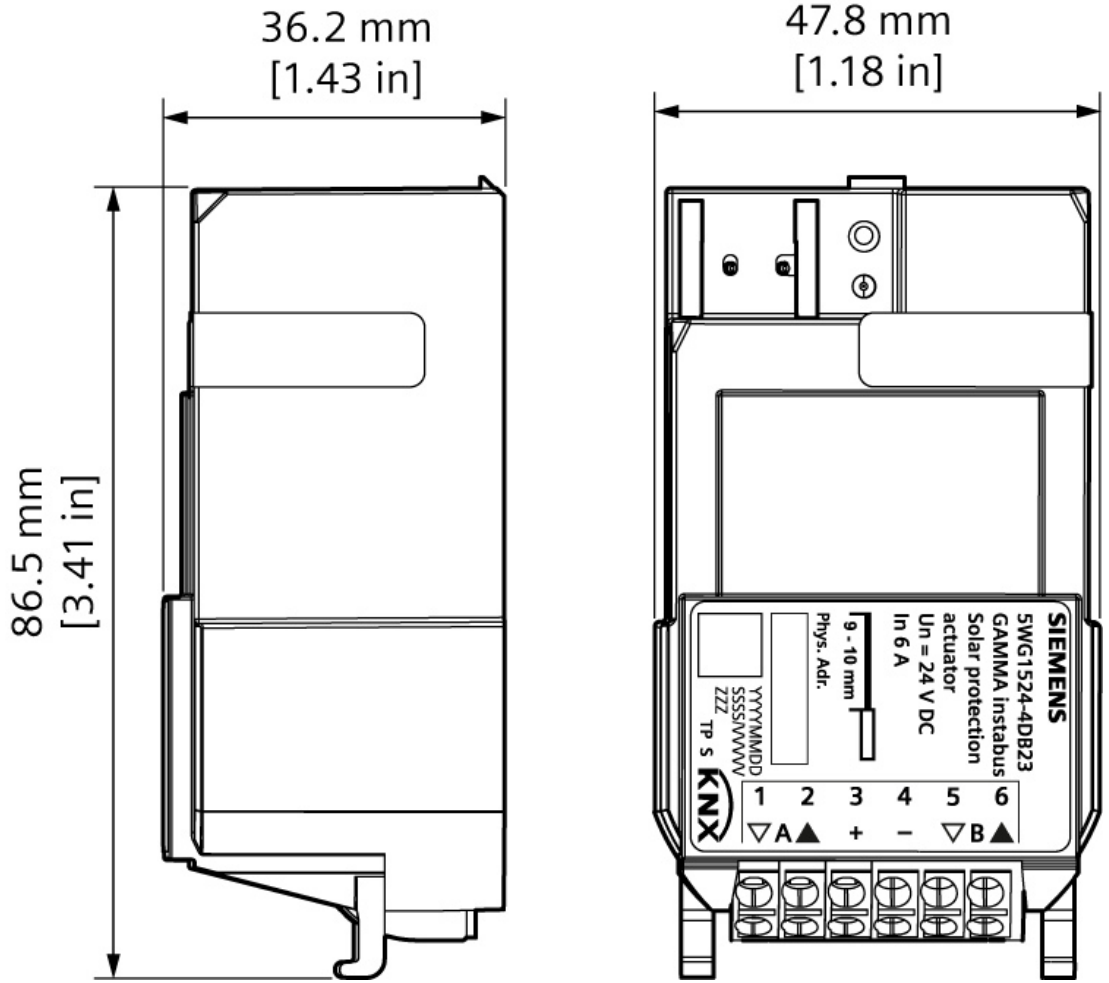

Compliance information

Issued by
Siemens Switzerland Ltd
Smart Infrastructure
Global Headquarters
Theilerstrasse 1a
CH-6300 Zug
+41 58 724 2424
www.siemens.com/buildingtechnologies

© Siemens 2023
Technical specifications and availability subject to change without notice.

Document ID A6V12883339_en--_b
Edition 2023-10-27